



Reinventing the drug carrier

In **Italy** there are about 2000
nutraceutical companies
that could save
8.6 B€ yearly!

The **vast majority** of them use obsolete methods that **lack of efficiency**, due to:

The **vast majority** of them use obsolete methods that **lack of efficiency**, due to:

Several steps
of production

The **vast majority** of them use obsolete methods that **lack of efficiency**, due to:

Several steps
of production

High solvent
residue

The **vast majority** of them use obsolete methods that **lack of efficiency**, due to:

Several steps
of production

High solvent
residue

Low
sustainability

This leads to a **low bioavailability** of active ingredients

Active ingredients

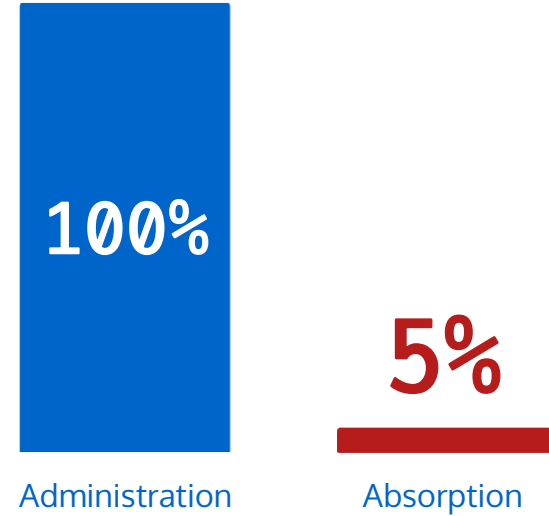

To improve bioavailability we use
drug carriers
that protect, transport and
enhance the efficacy of the
encapsulated molecules

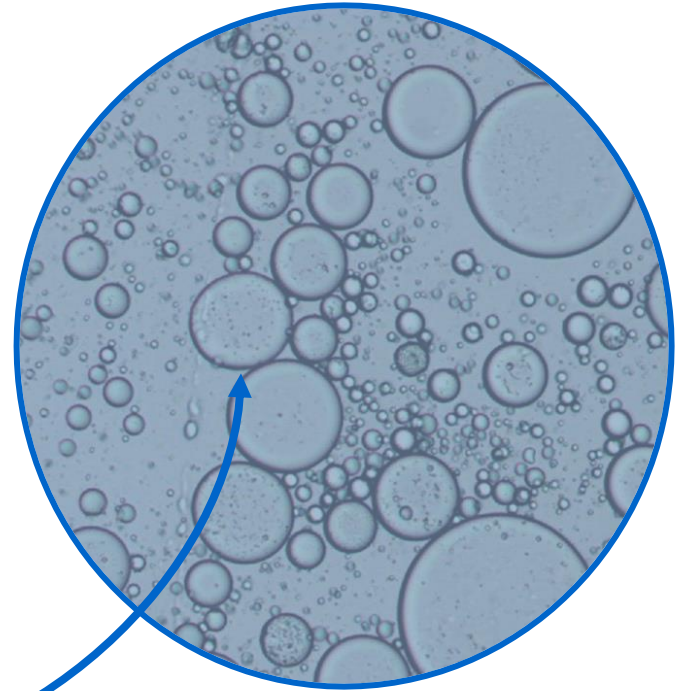

but not all drug
carriers are the same!

with **our** patented
technology
we managed to **solve**
all these drawbacks

with **our** patented
technology
we managed to **solve**
all these drawbacks

One-shot
production

with **our** patented
technology
we managed to **solve**
all these drawbacks

One-shot
production

Reduced cost

with **our** patented
technology
we managed to **solve**
all these drawbacks

One-shot
production

Reduced cost

Zero solvent
residue

which leads to a **better bioavailability** of the administered active ingredients

Active ingredients

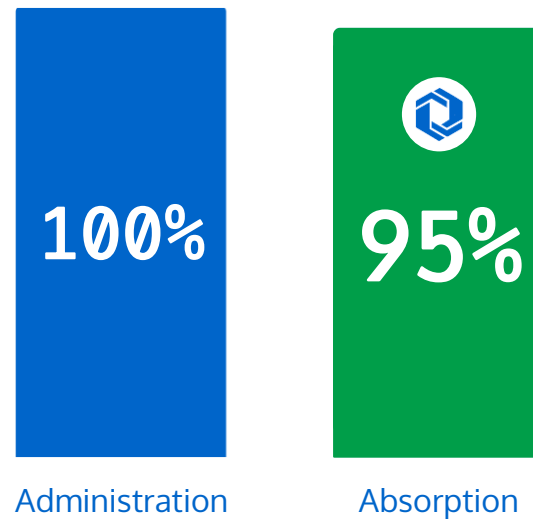

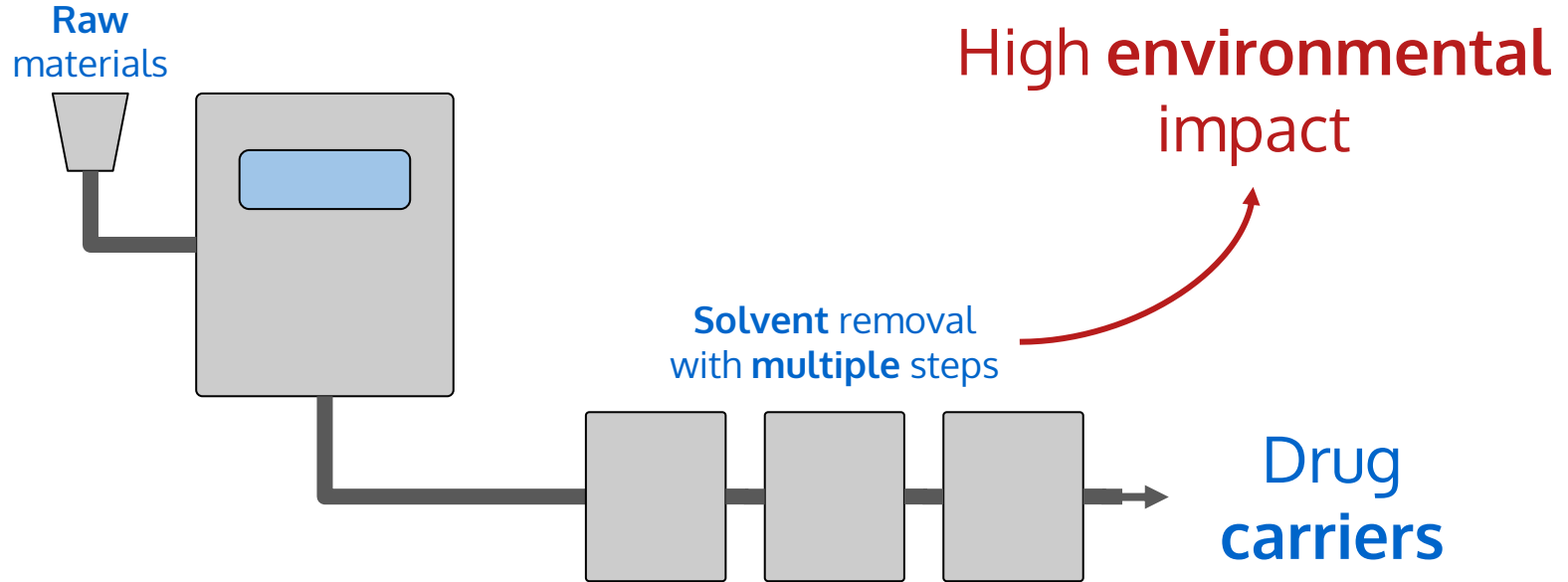

Other plants

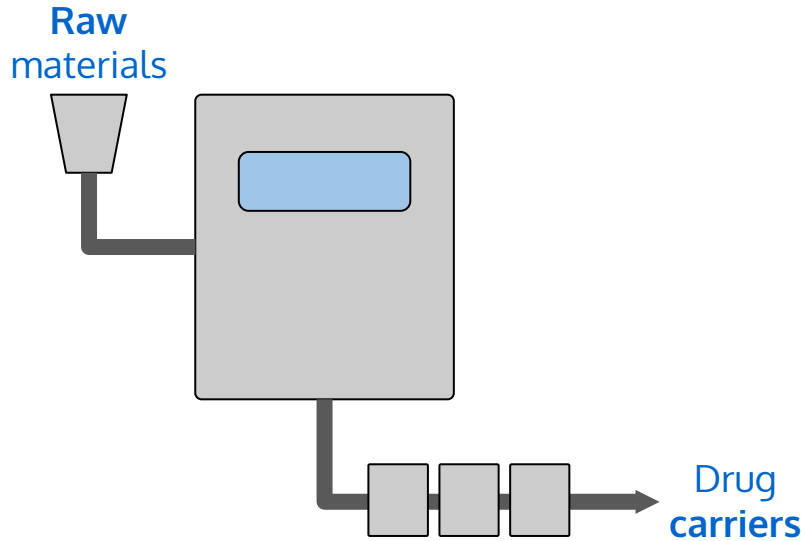

Iodo's plant

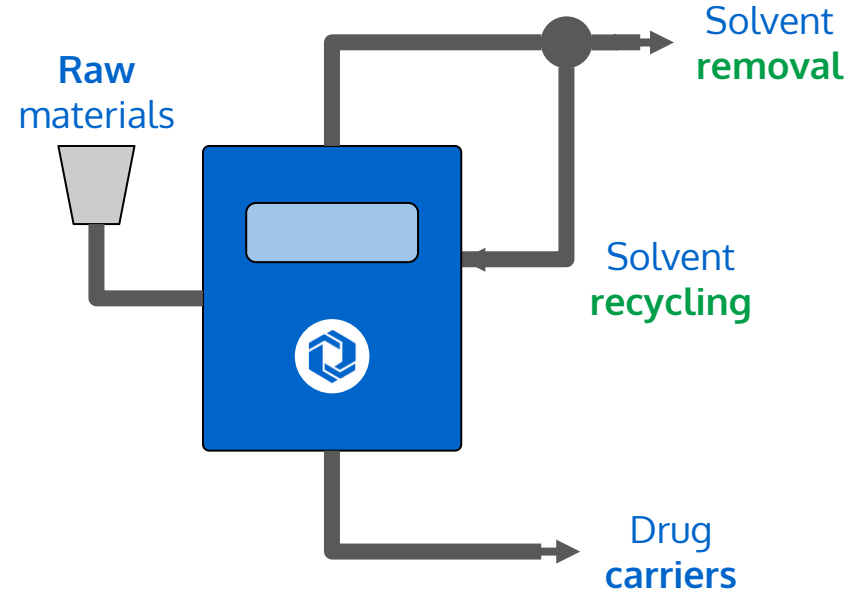

Our plant is
patented,
scalable
and versatile

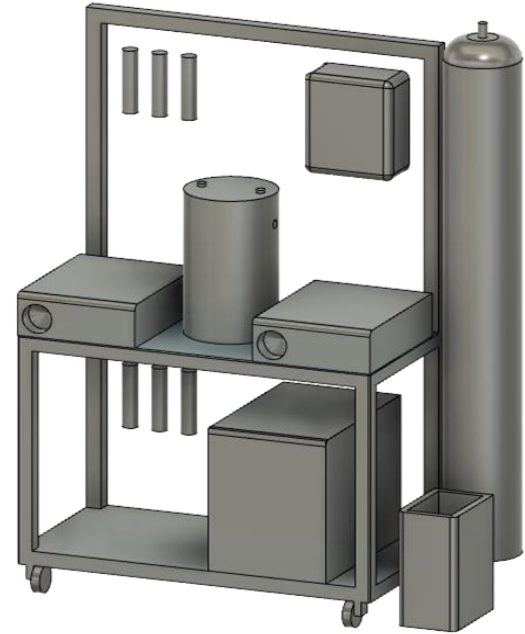



Sources:

<https://www.grandviewresearch.com/industry-analysis/nutraceuticals-market>
<https://finnicaconsulting.com/it/what-is-happening-in-the-italian-nutraceutical-market/>

Competitors

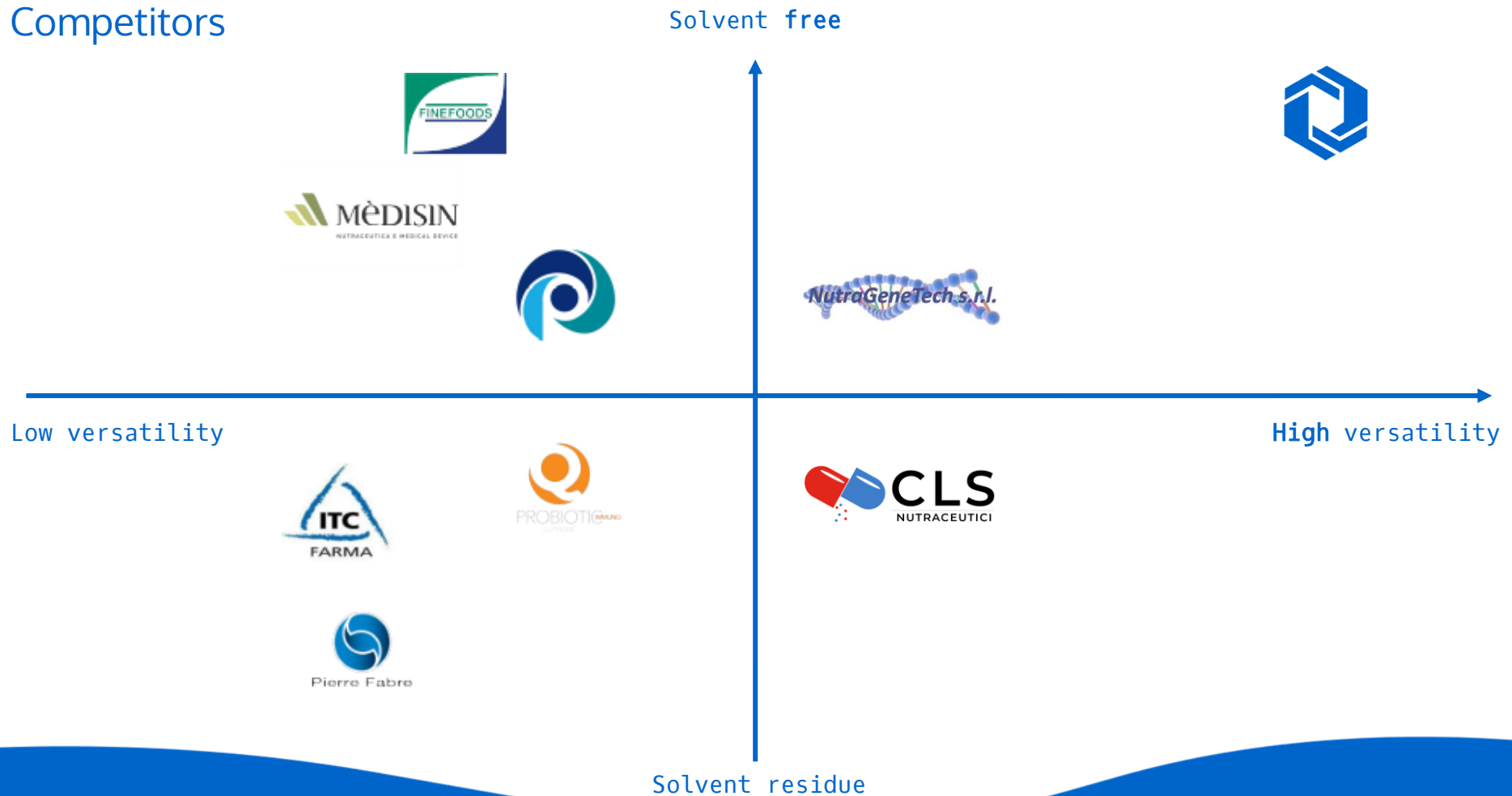

Acquisition
via
platform

Study of
the
molecule

Production
with 50%
contribution
margin

Customer acquisition

Setup study

Production



Massimo Moffa

IT Specialist

25,5%



Daniele Sofia

PhD Industrial Engineer

25,5%

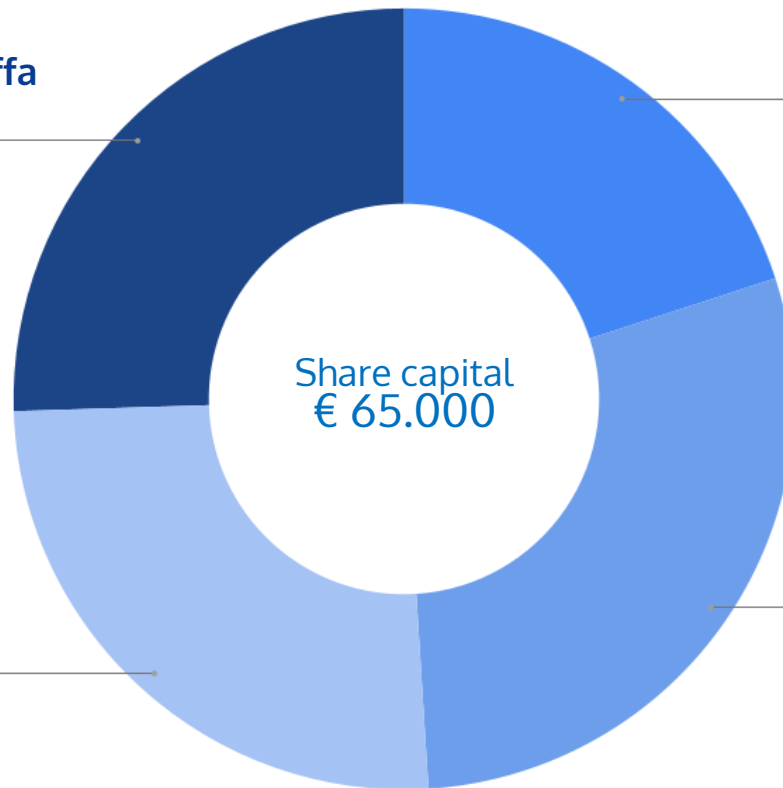

Rebirth srl

Business angel

20,0%



Paolo Trucillo

PhD Industrial Engineer

29,0%

Feb 2021

Foundation



May 2021

First international customer



Jun 2021

Patents

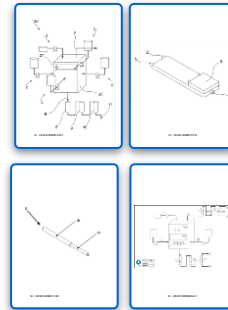

Jun 2023

Platform launch

Late 2024

Pilot plant

Working with the lab-scale plant while building the pilot plant

Financial need

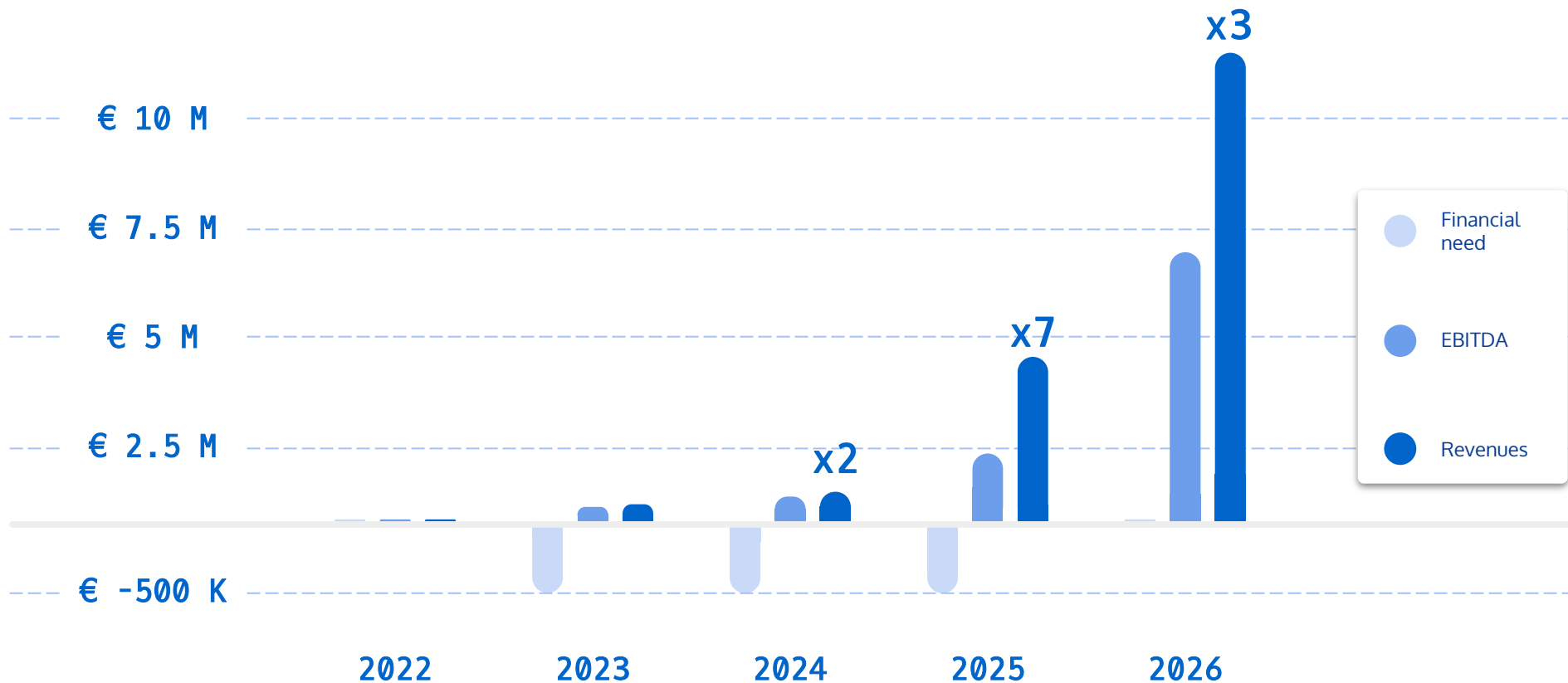

€ 500K
is our financial ask

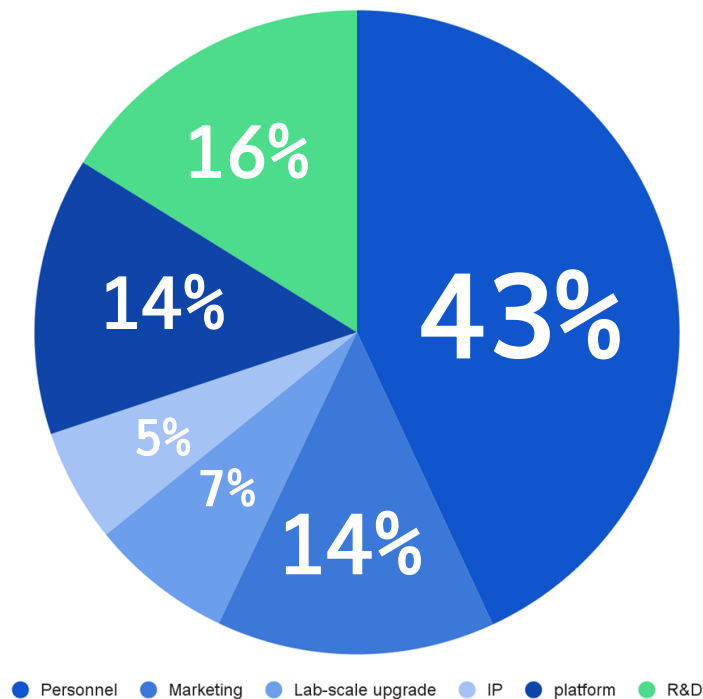

The process today



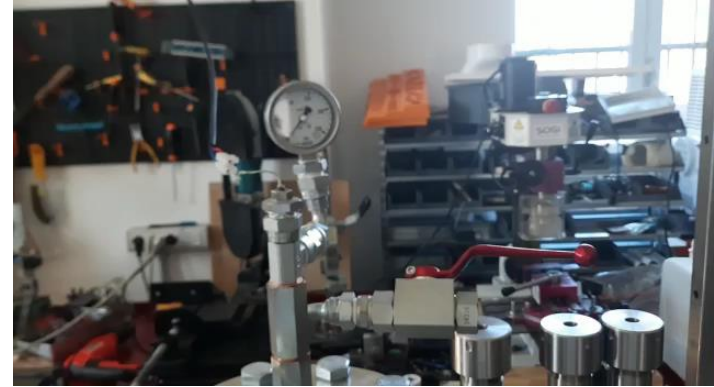

If you want
to know more...



Email
comunicazioni@iodo.tech

Website
www.iodo.tech



LinkedIn

Mobile
+39 329 65 66 043

Headquarters
Salerno, SA